

# HANGING SCALE

## OCS-L

### Features

- Aluminum die-casting case
- 20 mm LCD display with backlight
- Stainless steel shackle and hook
- AA \*3 battery

### Functions

- Zero
- Tare
- Hold
- Auto power-off
- Battery supervision
- Overload alarm
- Unit switch

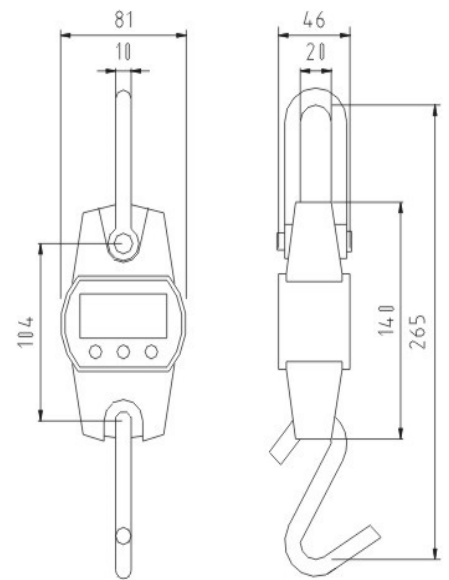

### Specification

Tare Range	100% F.S.
Zero Range	4% F.S.
Safe Overload	120% F.S.
Overload Alarm	100% F.S. +9e
Battery	AA *3
Battery Life	>100h
Temperature Range	-10 - 40
N.W.	650g

Max Capacity	Min Capacity	Graduation
kg	kg	kg
30	0.2	0.01
50	0.4	0.02
150	1	0.05
300	2	0.1

