

Ohaus SD Series

Shipping Scale



Now also available with larger plate



The Ohaus SD Series Shipping Scale – Portability, Durability, Ohaus quality and Value

The SD Series is a well-built portable bench scale designed specifically with affordability, utility and everyday usage in mind. Ideal for home office, mail room, shipping and receiving, and general commercial and industrial weighing applications, the SD series features a durable painted steel platform, remote indicator with two tactile function keys, battery operation and flexible mounting capability. The SD is now available in two plate sizes for even more versatility.

Standard Features Include:

- ✓ 3 popular capacity models: 35kg, 75kg, 200kg
- ✓ 2 Platform sizes: 316 x 280mm and 520 x 400mm (75kg & 200kg only)
- ✓ AC adapter included, or 360 hour battery operation with auto-shut off
- ✓ ABS plastic indicator housing with reinforced ribs
- ✓ Universal table/wall mounting brackets included
- ✓ Flexible coiled cable, extendable
- ✓ LCD with fast weight display in kg or lb
- ✓ Simple 2 function raised tactile keys
- ✓ Maximum displayed resolutions from 1:1650 to 1:2200
- ✓ Industry leading support

The Ohaus SD shipping scale

Specifications

Model	SD35	SD75	SD200	SD75L	SD200L
Capacities / Divisions	35kg x 0.02kg	75kg x 0.05kg	200kg x 0.1kg	75kg x 0.05kg	200kg x 0.1 kg
Price (ex vat)	call	Call	Call	Call	call
Maximum weight	35kg	75kg	200kg	75kg	200kg
Base Size (LxWxH)	316 x 280 x 45mm			520 x 400 x 75 mm	
Construction	ABS plastic housing and mounting brackets. Painted steel base				
Weighing Units	kg, lb				
Application Modes	Weight only				
Linearity	± 1d				
Repeatability (std. dev)	1d				
Display	LCD Display, 20mm high, 4-Digit, 7-Segment				
Keyboard	2 function raised tactile mechanical switches: [ON/OFF Zero] / [UNITS Cal]				
Zero range	To capacity by subtraction				
Stabilization time	<3 Seconds				
Cable length	Extendable 1.8m to 2.7m (full extension)				
Operating Temperature	5° to 40°C 10%-80% relative humidity, non-condensing				
Power	AC Adapter 9V DC / 100mA 3 "C" Alkaline batteries (<i>not included</i>)				
Battery operating time	360 hours				
Aton shut off	4 minutes with no activity (battery operation only)				
Safe overload capacity	150% of capacity				
Indicator size	210L x 91W x 39H mm				
Shipping dimensions	380L x 100W x 465H mm			600L x 480W x 230H mm	
Net weight	2.6 kg	3.3 kg		14 kg	
Shipping weight	3.7 kg	4.3 kg		16 kg	
Other features	Calibrate in kg or lb, Calibration lock via internal switch				

Outline Dimensional Drawings

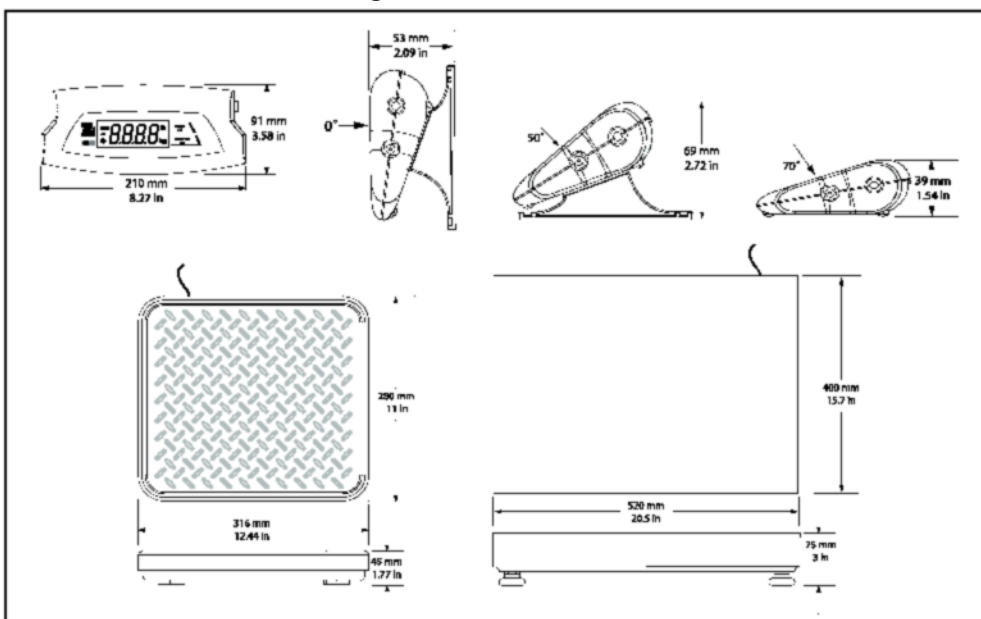

E. H OAKLEY & CO LTD
 43 Edison Road
 Rabans Lane Industrial Estate
 Aylesbury, Bucks, HP19 8TE
 Tel: 01296 393133

80774233A 11.2006 © Copyright Ohaus Corporation

www.ohaus.com

ISO 9001:2000
 Registered Quality Management System

