



Defender[®] 5000

Washdown Bench Scales



Multifunctional Stainless Steel Washdown Bench Scale for Standard Industrial Applications

The OHAUS next generation Defender 5000 Series multifunctional washdown bench scale is ideal for a multitude of applications, including production, packaging, inventory and shipping. Built durably and equipped with advanced features such as maximum configurability print output, GMP/GLP data output, library/user management, and multiple connectivity options - the Defender 5000 is designed to simplify demanding industrial and commercial applications.

Standard Features:

- **Indicator Guides The User with On-Screen Prompts**
See results clearly on the large backlit display. The alpha-numeric keypad and function keys allow for a simplified user experience. On-screen prompts and soft keys will guide you through the operation.
- **Durably Constructed To Withstand Harsh Industrial Environments**
Durably constructed with a stainless steel platform, frame, IP67 loadcell and IP68 indicator, the Defender meets OIML/EC Type approvals.
- **Multiple Application Modes and High Storage Capacity for Greater Flexibility**
Features common industrial modes and supports a 50,000 item library and 1,000 user profiles which can be downloaded/uploaded for easy set-up (with SD card.) Also equipped with GMP/GLP capability with time/date for result traceability.
- **Multiple Connectivity Options for Convenient Data Transfer and Storage**
Results can be stored in the MicroSD card. Data output by built-in RS232 or optional interfaces including 2nd RS232/485/USB Device, Ethernet, Bluetooth/WiFi, Analog Output and Discrete I/O with relays.

Ingeniously Practical

Defender[®] 5000 Washdown Bench Scales

Simplified Use

Results can be read easily on the Defender 5000's large transfective dot matrix display, even in bright sunlight. The SmarText 3.0 interface will guide you through all of the Defender 5000's unique and advanced features. With five soft keys, SmartText 3.0 makes an advanced scale very simple to use, and reduces training time for operators.



Durable Construction

With OIML/EC-type approvals, the Defender 5000 can be used for both general and legal-for-trade applications. For standard industrial applications, the Defender 5000 bench scales offer durable performance at a practical price.



Simple Operation

Featuring most common applications including Percent Weighing, Parts Counting with APW optimization, Checkweighing or Checkcounting and Dynamic Weighing or Display Hold, the Defender 5000 meets the weighing and measurement needs of practically every industrial application or manufacturing process. Many application modes eliminate the need for long and complicated manual calculations. GMP/GLP with time/date allows for traceability of results.

Equipped with Micro SD card, the Defender 5000 can support storage of up to 50,000 items and 1,000 user profiles. Weighing results can also be stored in Alibi or regular format, addressing all your data storage needs.



Multiple Connectivity Options

Weighing results can be easily exported through the standard RS232 port. Additional connectivity options include a second RS232, RS485 or USB device; Ethernet, and WiFi/Bluetooth.

Using the Analog option (either 4-20mA or 0-10V) or the two In/four Out discrete I/O, the new Defender 5000 indicator can also be used for systems including PLCs.



Indicator Specifications

TD52XW	
Construction	304 stainless steel with sand blasted surface treatment
Protection	IP68
Weighing Units	lb, oz, lb:oz, kg, g, metric ton, short ton, custom unit
Application Modes	Basic weighing, Percent weighing, Piece Counting with Optimized APW, Animal weighing/Dynamic weighing, Check weighing
Display	Dot matrix LCD with white LED backlight, 256 x 80 pixels
Keyboard	6 function, 5 quick, 12 alpha numeric membrane switches
Auto-zero Tracking	Off, 0.5 d, 1 d or 3 d
Zeroing Range	2% or 100% of capacity
Interface	Standard RS232, Optional Ethernet, WiFi/Bluetooth, 2 nd RS232/RS485/USB, Analog output, 2 In/4 Out digital I/O
Power	100-240 VAC / 50/60 Hz Universal Power Supply, hardwired, rechargeable lithium battery (Optional)
Battery Life	20 hours continuous use
Calibration	Zero, Span or 3 point-Linear

Defender® 5000 Washdown Bench Scales

Front Mount Bench Scale Specifications

Model	D52XW6WQDR5	D52XW15WQDR5	D52XW15WQDL5	D52XW30WQDL5	D52XW60WQDL5	D52XW60WQDX5	D52XW150WQDX5
Capacity × Readability	3/6 kg × 0.2/0.5 g 6/12 lb × 0.0005/0.001 lb	6/15 kg × 0.5/1 g 12/30 lb × 0.001/0.002 lb		15/30 kg × 1/2 g 30/60 lb × 0.002/0.005 lb	30/60 kg × 2/5 g 60/120 lb × 0.005/0.01 lb		60/150 kg × 5/10 g 120/300 lb × 0.01/0.02 lb
Min APW (g)	0.01	0.025		0.05	0.1		0.25
Internal Counting Resolution	1:600000						
Certified Model	D52XW6WQDR5-M	D52XW15WQDR5-M	D52XW15WQDL5-M	D52XW30WQDL5-M	D52XW60WQDL5-M	D52XW60WQDX5-M	D52XW150WQDX5-M
Certified Capacity × Readability	3/6 kg × 1/2 g	6/15 kg × 2/5 g		15/30 kg × 5/10 g	30/60 kg × 10/20 g		60/150 kg × 20/50 g
Min APW (g)	0.05	0.1		0.25	0.5		1
Internal Counting Resolution	1:120000	1:150000		1:120000		1:150000	
Linearity/ Repeatability	± 2d						
Indicator	TD52XW						
Mount	Stainless steel front-mount bracket with handle						
Base Construction	Stainless steel removable weighing platform with stainless steel frame, silicon sealed IP67 aluminum loadcell						
Safe Overload Capacity	150% of maximum capacity						
Stabilization Time	Within 1 second						
Operating Temperature Range	-10°C to 40°C						
Scale Dimensions (B × A × C × D × E × F)	305 × 305 × 95 × 60 × 118 × 588 mm		400 × 400 × 110 × 70 × 118 × 677 mm			500 × 500 × 120 × 80 × 118 × 772 mm	
Shipping Dimensions (L × W × H)	480 × 445 × 363 mm		800 × 600 × 235 mm			994 × 680 × 235 mm	
Approx. Net Weight	9 kg		17 kg			21 kg	
Approx. Shipping Weight	11 kg		19 kg			24 kg	

Model	D52XW15WQR5	D52XW15WQL5	D52XW30WQL5	D52XW60WQL5	D52XW60WQX5	D52XW150WQX5	
Capacity × Readability	15 kg × 1 g 30 lb × 0.002 lb		30 kg × 2 g 60 lb × 0.005 lb	60 kg × 5 g 120 lb × 0.01 lb		150 kg × 10 g 300 lb × 0.02 lb	
Min APW (g)	0.05		0.1	0.25		0.5	
Internal Counting Resolution	1:300000			1:240000		1:300000	
Certified Model	D52XW15WQR5-M	D52XW15WQL5-M	D52XW30WQL5-M	D52XW60WQL5-M	D52XW60WQX5-M	D52XW150WQX5-M	
Certified Capacity × Readability	15 kg × 5 g		30 kg × 10 g	60 kg × 20 g		150 kg × 50 g	
Min APW (g)	0.25		0.5	1		2.5	
Internal Counting Resolution	1:60000						
Linearity/ Repeatability	± 2d						
Indicator	TD52XW						
Mount	Stainless steel front-mount bracket with handle						
Base Construction	Stainless steel removable weighing platform with stainless steel frame, stainless steel load cell						
Safe Overload Capacity	150% of maximum capacity						
Stabilization Time	Within 1 second						
Operating Temperature Range	-10°C to 40°C						
Scale Dimensions (B × A × C × D × E × F)	305 × 305 × 95 × 60 × 118 × 588 mm		400 × 400 × 110 × 70 × 118 × 677 mm			500 × 500 × 120 × 80 × 118 × 772 mm	
Shipping Dimensions (L × W × H)	480 × 445 × 363 mm		800 × 600 × 235 mm			994 × 680 × 235 mm	
Approx. Net Weight	9 kg		17 kg			21 kg	
Approx. Shipping Weight	11 kg		19 kg			24 kg	

Defender[®] 5000 Washdown Bench Scales

Application Modes



Weighing: Determine the weight of items in the selected unit of measure.



Percent Weighing: Measure the weight of a sample displayed as a percentage of a pre-established reference weight.



Parts Counting: Count samples of uniform weight. Advanced auto-optimization software recalculates the average piece of weight as the overall weight increases.



Dynamic Weighing and Display Hold: Weigh an unstable load. Scale takes an average of weights over a period of time. The Display Hold feature manually and automatically holds the last stable weight on the display.



Checkweighing/Counting: Compare the weight/count of a sample against target limits. Connect with Discrete I/O and Light Tower Kit for external check lights.

Other Standard Features and Equipment

User-configurable resolution up to dual range 15,000d/3,000e, 150% overload capacity protection, checkweighing symbols with selectable operation and audible signal settings, menu lock switch, multiple selectable operating languages, selectable environmental and auto-print settings, stability indicator, overload/underload indicators, selectable adjust contrast settings, auto-dim display, auto-off, auto tare, 304-grade stainless steel platform and frame, stainless steel IP68 indicator, IP67 load cell, non-slip adjustable rubber feet, a Wheel Kit option is also available for scales up to 300 kg.

Additional Features

A total of six print templates are available to ensure you can print out all of the data you need. A simple template is predefined for quick printing, as well as five templates you can customize so you can print the exact information necessary for your application - eliminating confusion and time to sift through excess unnecessary data.

Compliance

- **Metrology:** OIML R76 (Indicators: Certificate R76/2006-A-NL1-18.13; Load Cells: Certificates R60/2000-NL1-12-41, R60/2000-NL1-12-42, R60/2000-NL1-12-43, R60/2000-NL1-14.24)
- **Product Safety:** IEC/EN 61010-1; CAN/CSA C22.2 61010-1; UL61010-1
- **Electromagnetic Compatibility:** IEC/EN 61326-1 Class B, basic environments; FCC Part 15 Class B; Canada ICES-003 Class B
- **Compliance Marks:** CE; CSA; RCM

Accessories

Battery Kit, Li-ion, TD52	30424405	Analog Output Kit, TD52 ³	30424403
USB Host for Dongle, TD52	30424406	Second RS232/RS485/USB Kit, TD52 ²	30424404
Light Tower, 3 Colors, 243mm, IP65 (Requires 30097591)	30424021	I/O with Relay (2 In/4 Out) ³	30097591
In-use Cover Kit, TD52P	30424022	WiFi/BT Dongle, OHAUS ² (Requires 30424406)	30412537
In-use Cover Kit, TD52XW	30424023	Ethernet Kit, D52 ²	30429666
In-use Cover set (10), TD52P	30469948	Wheel Kit, Defender Series ¹	30372146
In-use Cover set (10), TD52XW	30469949	Printer SF40A	30045641
Printer Holder Kit, D52	30424025		
Wall Mount Kit, SST, TD52XW	30424026		
Wall Mount Kit, CS, TD52P	30424027		
LC Extension Cable, 9 meters, D52 ¹	30424409		
M16 Gland with Ferrite, to TD52	30379716		
Micro SD Card, 8G	30303533		

¹ Cannot be used for legal-for-trade applications ² Only one of them can be used at the same time ³ Only one of them can be used at the same time

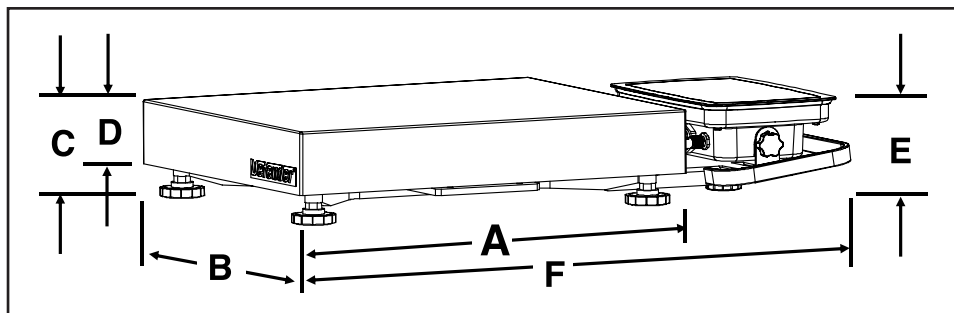

OHAUS Europe GmbH
Im Langacher 44
8606 Greifensee
Switzerland

e-mail: ssc@ohaus.com
Tel: 0041 22 567 53 19
e-mail: tsc@ohaus.com
Tel: 0041 22 567 53 20

www.ohaus.com

OHAUS Corporation is an ISO
9001:2008 manufacturer

ISO 9001:2008
Registered Quality
Management System

CH16B065

