



jumboweigher



A popular choice among steel service centres and other industrial manufacturers, the Jumboweigher crane scale from Straightpoint offers a cost-effective alternative to its more expensive rivals from MSI and Intercomp. The Jumboweigher series of crane scales offers high capacity, quality, accuracy, and safety at low capacity prices and are utilised worldwide in a variety of manufacturing and industrial applications.

As with all Straightpoint products each Jumboweigher crane scale receives superior electronics, excellent build quality and certified calibration and proof testing. The heavy duty crane scale is extremely accurate, and is manufactured from quality materials, featuring a high strength aluminium alloy outer housing.

Each unit is equipped with a large and bright LED display that can be easily read even in direct sunlight. The simple to use remote features oversized buttons for use with gloved hands and provides for control of tare and hold functions. Battery charging intervals are extended by the standby power saving mode as well as the automatic shut off feature. As with all Straightpoint products each Jumboweigher is safety tested and is supplied with certification of calibration and proof testing.

If you are looking for a high quality, cost-effective crane scale and are unwilling to give up features and safety, look no further than the Jumboweigher crane scale from Straightpoint.

Features and benefits:

- Large bright LED display
- High accuracy
- Aluminium housing
- Power saving mode
- Tare
- Hold function
- Large keys make operation simple even if wearing gloves

metric specifications

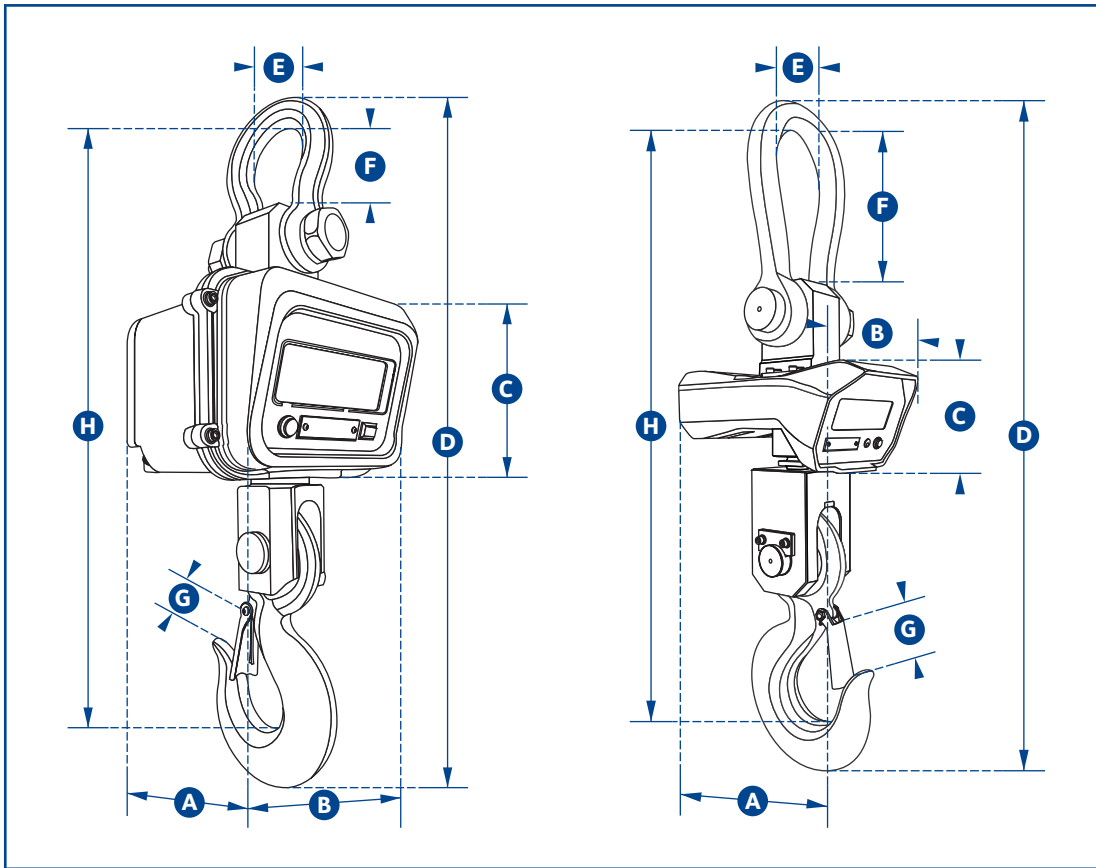

jumboweigher

Part Number	JW5T	JW10T	JW20T
Capacity	5000kg	10,000kg	20,000kg
Resolution	2kg	5kg	10kg
Units	kg		
Weight	18kg	29kg	75kg
Safety Factor	5:1		
Battery Type	Internal rechargeable		
Battery Life	20 hours		
Operating Temp	-10°C to +40°C		
Accuracy	±0.3% of applied load		
Display Type	30mm LED		
Protection	IP54		
Dimension A	195	195	355
Dimension B	225	255	230
Dimension C	180	180	165
Dimension D	715	780	1115
Dimension E	72	90	140
Dimension F	90	110	230
Dimension G	36	50	70
Dimension H	595	660	980