

# Model S100

## General Purpose Scale



- **Accuracy**– 0.01% of full scale
- **Capacity**– 75 kg / 150 lb, 150 kg / 300 lb and 300 kg / 600 lb
- **Construction**– Stainless steel weight platter, painted mild steel base, ABS indicator
- **Display**– Large, easy to read, bright red LED display
- **Power**– AC/Mains power and built-in rechargeable lead-acid battery
- **Operator Keys**– Power/Zero, Tare, Units, Hold/Print
- **Platform Length**– 457 mm x 559 mm 18" x 22"
- **RS-232**– Standard

# S100 General Purpose Scale

## Features

The S100 is a low cost general purpose, self-contained industrial scale with RS-232 interface for simple non-trade weighing applications.

**Column or Desk Mount Indicator:** Attach the indicator to the stainless steel column to provide a total height of 927 mm / 36.5" or remote the indicator up to 1220 mm / 48" without the use of column

**RS-232 Interface:** SBI 100 indicator can be configured for weight only or GTN via continuous output, print key, or stable weight. Choose bi-directional interface for communication to a PC

**ON/OFF Switch:** Remove power from indicator to increase battery performance and life of product

**Auto Shut-off Timer:** Adjustable from 1-15 minutes or Off

**Weight Hold Functions:** Can be configurable for manual button release, automatic release on change in weight, or within +/- 3-50 scale divisions

**Internal Rechargeable Battery:** Low battery and battery charging annunciators indicate status of lead-acid battery. Battery is charged while AC power is active.

**Units Switching:** Can be configured for LB/KG switching, LB only, or KG only

**Adjustable Resolution Setting:** Factory default setting of 6,000 or 7,500 divisions can be modified to increase performance within certain applications

**Adjustable Scale Setting:** Power on zero, AZT, 4 filter settings, weight stability, overload, baud rate and status bits

**Robust Design:** Re-enforced painted mild steel base, stainless steel weight platter and pole, robust ABS plastic indicator with strain relief connections, and heavy duty adjustable foot assemblies

### Dimensions

A = 22" (559 mm)  
B = 18" (457 mm)  
C = 5" (127 mm)

### Indicator

D = 9.75" (248 mm)  
E = 5.5" (140 mm)  
F = 5.75" (140 mm)  
G = 36.5" (927 mm)

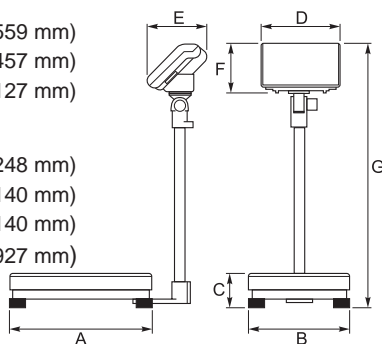

## Specifications

**Capacity:** 75 kg x 0.01 kg / 150 lb x 0.02 lb  
150 kg x 0.02 kg / 300 lb x 0.05 lb  
300 kg x 0.05 kg / 600 lb x 0.1 lb

*The Model S100 is non-trade approved*

**Construction:** Mild steel base, stainless steel top cover and display pole, ABS plastic indicator

**Tare:** 100% subtractive

**Display:** Six digit 20 mm / 0.8" high red LED display with 8 separate LED annunciators

**Annunciators:** Net, zero, kg, lb, hold, low battery, battery charging, mains connected

**RS-232:** Standard 9 pin straight pass through interface connector, interface cable not included

**Function Keys:** Power Switch, On/Off/Zero, Tare, Units, Hold/Print

**Auto-off:** Selectable between 1 to 15 minutes after inactivity

### Power:

North America: 120V AC @ 60Hz, 12 VDC, 500mA UL Approved wall mount power adapters

UK/EU: Version Power Supply 230V @ 50 Hz 12 VDC, 500mA, CE approved 3 pin UK and 2 pin EU 230V wall mount power adapters

AUS/SA: Version Power Supply 100-240V @ 50/60Hz, 12 VDC, 500mA, C-tick approved 3 pin Australian and a 3 pin South African wall mount power adapters

**Battery Life:** Up-to 35 hours of continuous use

**Operating Temperature:** 5° C to 35° C / 41° F to 95° F

**Weight:** 20 kg / 44 lb

### Packaging Dimension:

965 mm (L) x 610 mm (W) x 203 mm (H)  
35" L x 24" W x 8" H

**Shipping Weight:** 24 kg / 53 lb

**Packaging Contents:** SBI 100 indicator, S100 base with load cell interface cable, power supply(s), SS mounting pole, indicator mounting hardware.

**Certification:** Full FCC compliance, UL/CUL power adapter, CE, WEEE directive



a division of Avery Weigh-Tronix, LLC

## Brecknell

1000 Armstrong Dr., Fairmont, MN 56031  
Toll free: 800-637-0529, Tel: 507-238-8702  
Fax: 507-238-8271  
e-mail: sales@brecknellscales.com  
www.brecknellscales.com



## Brecknell

Foundry Lane, Smethwick  
West Midlands B66 2LP UK  
Tel: +44 (0) 845 246 6717  
Fax: +44 (0) 845 246 6718  
Email: sales@brecknellscales.co.uk  
www.brecknellscales.co.uk

