

# S133

## Bench Scale



- **OIML Approved**– 3000 division approved, 6000 divisions unapproved
- **Capacity**–
  - 60 kg x 0.01 kg (unapproved)
  - 150 kg x 0.02 kg (unapproved)
  - 300 kg x 0.05 kg (unapproved)
  - 60 kg x 0.02 kg (approved)
  - 150 kg x 0.05 kg (approved)
  - 300 kg x 0.1 kg (approved)
- **Construction**– Die cast base, ABS plastic indicator, stainless steel platter
- **Power**– Powered by either the internal rechargeable battery or 12 VDC, 500mA, power adapter
- **Display**– 52 mm / 2" high, 7 segment LCD display with LED annunciator and configurable backlight
- **Operator Keys**– Gross/Net, Print, Memory Recall, Accumulate, Tare, Zero, On/Off

# S133 Bench Scale

## Specifications

**LED Annunciators:** Over, Under, Accept

**Tare:** 100% subtractive

**RS-232 Option**

**Adjustable feet and level Indicator:** Four adjustable feet and level indicator at base of pole to ensure maximum stability

**Adjustable Indicator:** Mounted to a stainless steel column that can be tilted throughout approximately 150° range for easy visibility

**Check Weighing:** Simple check weighing feature with built in annunciators for target setting and configurable audio alarm

**Weight Accumulation and Totalizer:** Allows the number of weighings and the total amount of weight to be stored and recalled

**Internal Rechargeable Battery:** 6 VDC rechargeable battery. 12 hours to fully charge the scale. Approximately 20 hours of continuous battery life

**Operating Humidity:** 0 to 85% RH (non-condensing)

**Operating Temperature:**

-10° C to 40° C / 14° F to 104° F

**Platter Dimension:**

520 mm x 420 mm / 20.5" x 16.5" with 660 mm / 26" column.

**Packaging Dimension:**

820 mm x 590 mm x 250 mm / 32.3" x 23.2" x 9.8"

**Shipping Weight:**

Net – 13.5 kg / 29.8 lb

Gross – 16.4 kg / 36.2 lb

**Cerifications:** CE approved power adapters, EC #UK2863, OIML R76/1992-GB1-09.08

**Product Code:**

816965004652: 60 kg (unapproved)

816965004669: 150 kg (unapproved)

816965004676: 300 kg (unapproved)

AWT05-504543 (approved)

AWT05-504544 (approved)

AWT05-504545 (approved)

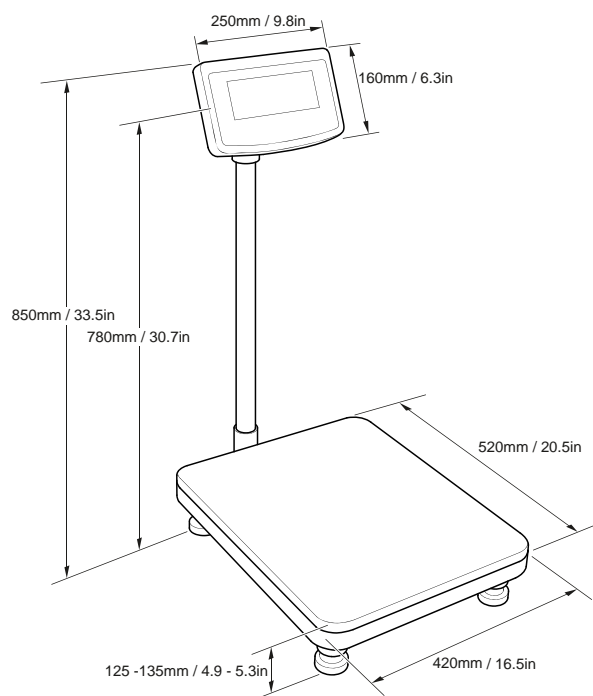

a division of Avery Weigh-Tronix, LLC

**Brecknell**

1000 Armstrong Dr., Fairmont, MN 56031  
Toll free: 800-637-0529, Tel: 507-238-8702  
Fax: 507-238-8271  
e-mail: sales@brecknellscales.com  
www.brecknellscales.com



**Brecknell**

Foundry Lane, Smethwick  
West Midlands B66 2LP UK  
Tel: +44 (0) 845 246 6717  
Fax: +44 (0) 845 246 6718  
Email: sales@brecknellscales.co.uk  
www.brecknellscales.co.uk

